

1-800-639-2199

Fax (603) 224-2927

Headwalls\Standard\Wing Walls\48 in_Pipe_Wing Wall with Base (v)

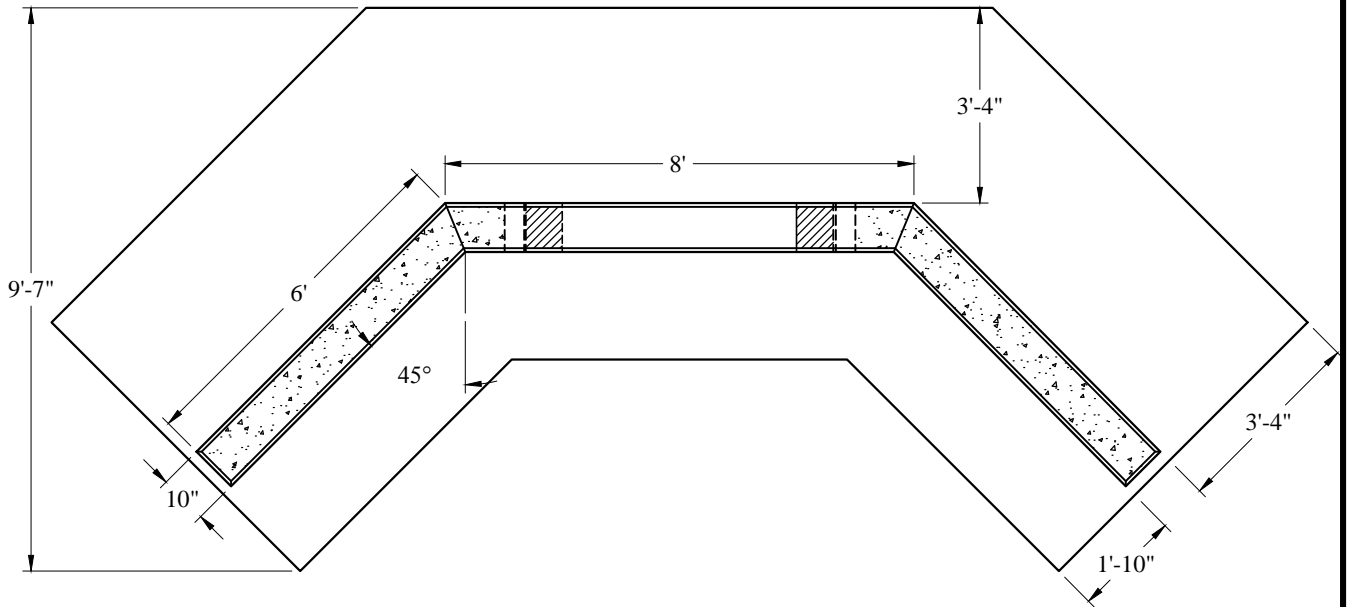

Phoenix Precast Products

Phoenix Precast Products

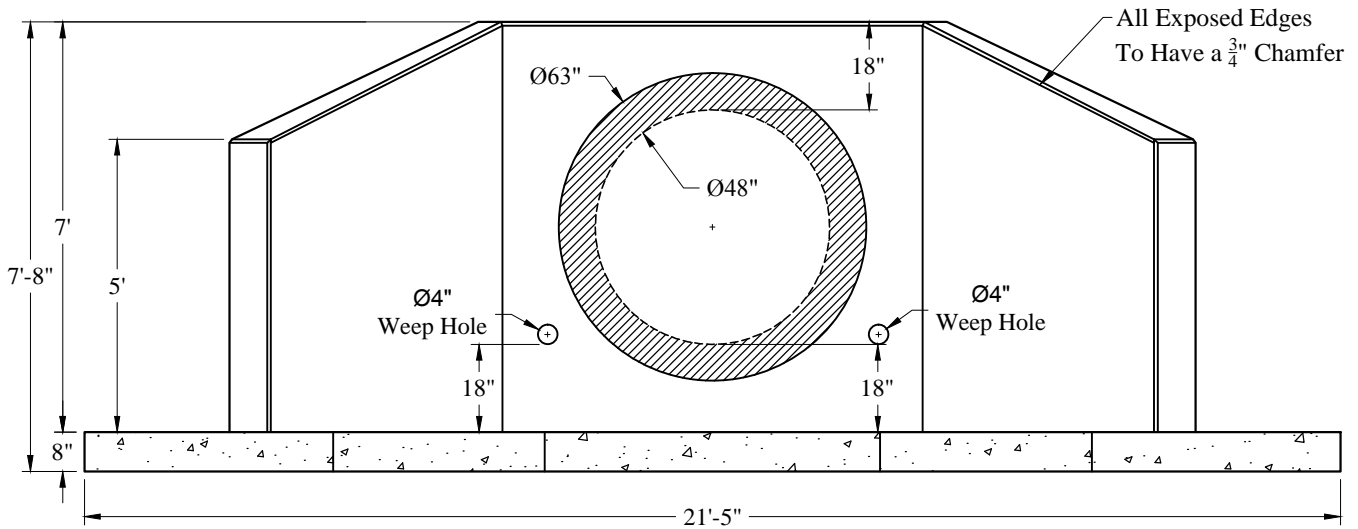

Est Weight: 24,770 Lbs

General Notes

1. Precast Concrete Shall Conform to AASHTO M 199. Concrete Shall be Class AAA (f'c = 5000 psi)
2. Reinforcing Steel Shall Conform to AASHTO M 31, ASTM A-615 Grade 60 Black Deformed Bars
3. All Exposed Corners to Have a $\frac{3}{4}$ " Chamfer

Phoenix
Precast
Products

48" RCP Winged
Headwall with Base

P/N: HWW-48B